

THIS DRAWING IS UNPUBLISHED. RELEASED FOR PUBLICATION ,19 .
 © COPYRIGHT 19 BY AMP INCORPORATED. ALL RIGHTS RESERVED.

LOC	DIST	REVISIONS					
		P	LTR	DESCRIPTION	DATE	DWN	APVD
AF	50		H2	REV UPDATE PER ECR 05-015567	16NOV05	JR	DD

- 1 CONTINUOUS STRIP ON REELS.
- 2 WIRE SIZE IS [#24-#20] AWG.
- 3 INSULATION RANGE IS 2.03-2.54 [.080-.100] DIA.

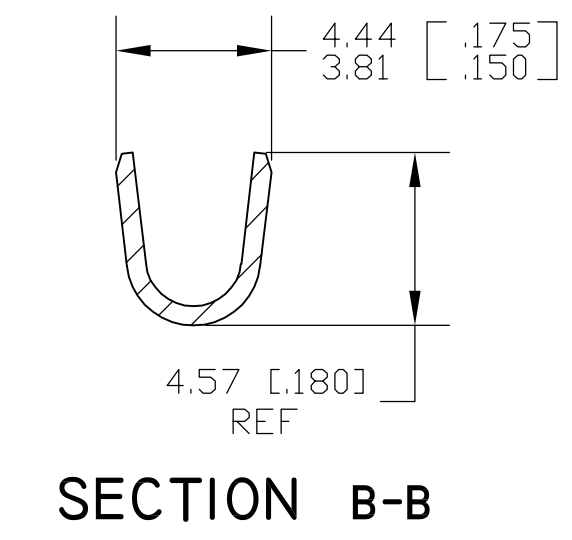
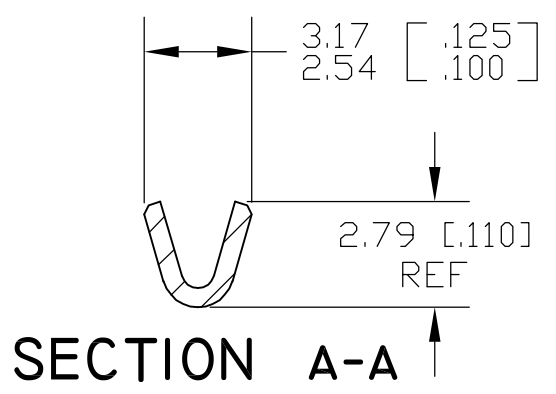
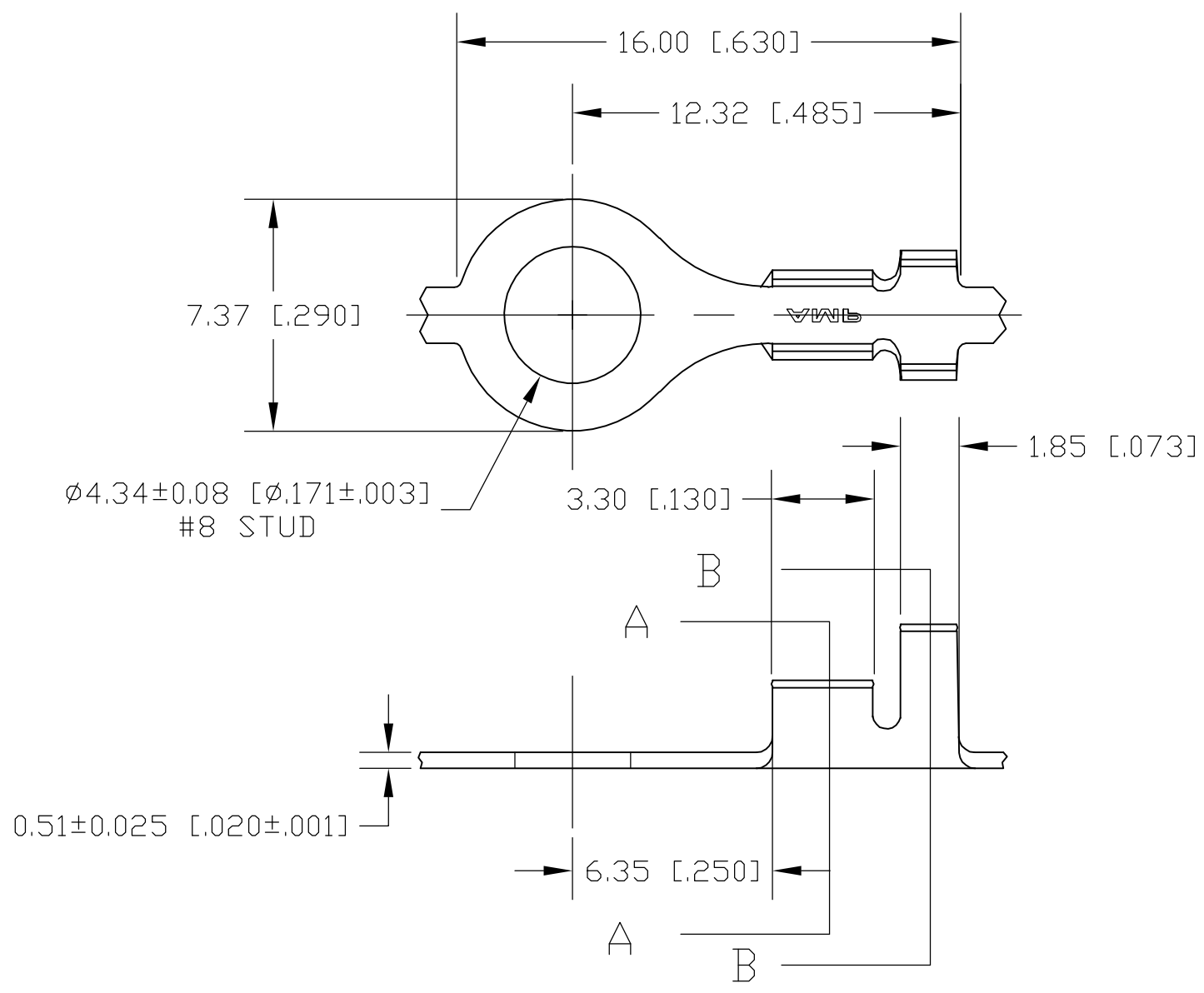

41581
PART NO.

THIS DRAWING IS A CONTROLLED DOCUMENT.		DWN J RUTH 04AUG00	AMP AMP Incorporated Harrisburg, PA 17105-3608													
DIMENSIONS: MM [INCHES]		CHK MS FEHER 04AUG00														
TOLERANCES UNLESS OTHERWISE SPECIFIED:		APVD D DECKER 04AUG00	NAME RING TONGUE													
<table border="0"> <tr><td>0 PLC</td><td>± -</td></tr> <tr><td>1 PLC</td><td>± -</td></tr> <tr><td>2 PLC</td><td>± 0.38 [.015]</td></tr> <tr><td>3 PLC</td><td>± -</td></tr> <tr><td>4 PLC</td><td>± -</td></tr> <tr><td>ANGLES</td><td>± -</td></tr> </table>		0 PLC	± -	1 PLC	± -	2 PLC	± 0.38 [.015]	3 PLC	± -	4 PLC	± -	ANGLES	± -	PRODUCT SPEC -	SIZE A3	
0 PLC	± -															
1 PLC	± -															
2 PLC	± 0.38 [.015]															
3 PLC	± -															
4 PLC	± -															
ANGLES	± -															
MATERIAL 082 BRASS		APPLICATION SPEC -	CAGE CODE 00779	DRAWING NO C-41581												
FINISH TIN PLATED		WEIGHT	RESTRICTED TO -													
CUSTOMER DRAWING			SCALE 5:1	SHEET 1 OF 1												
			REV H2													